

FLOOR PLAN

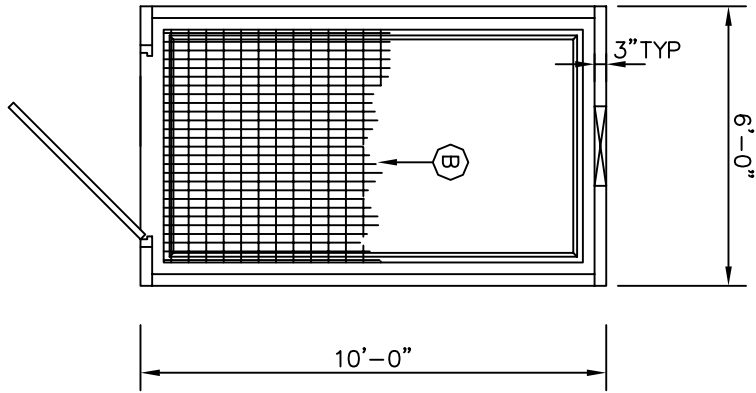

LEFT ELEV.

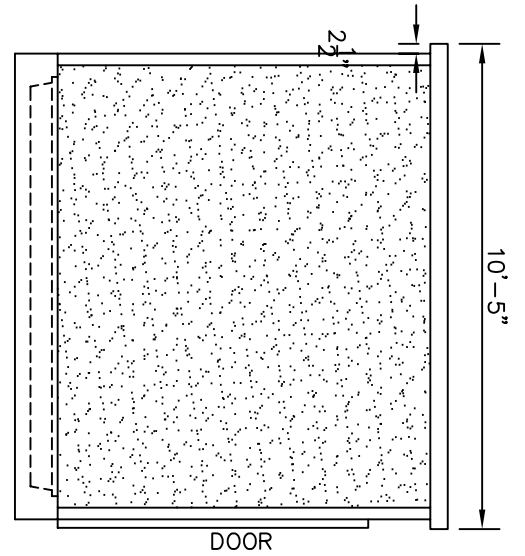

DOOR

FRONT ELEV.

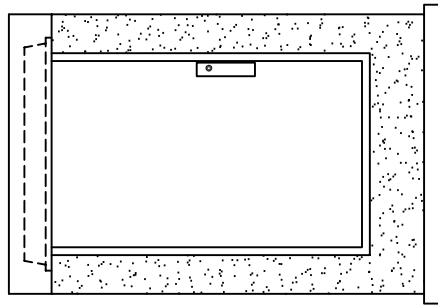

RIGHT ELEV.

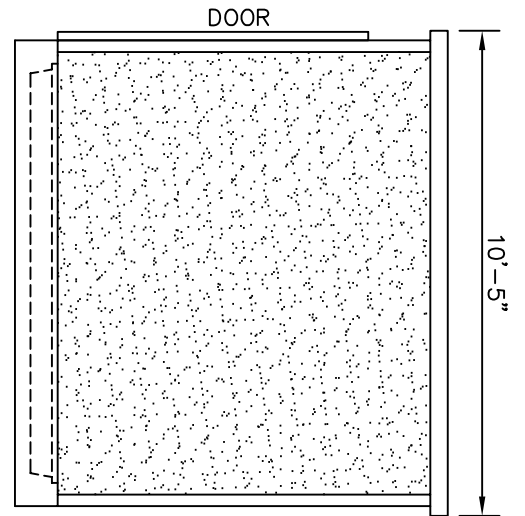

DOOR

BACK ELEV.

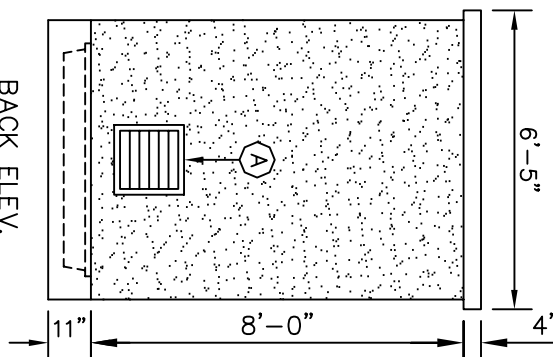

NOTES:

- A: 18" X 18" FUSIBLE LINK VENT
- B: BLACK STEEL GRATING, 1" THICK (STANDARD)

REV	DATE	DESCRIPTION
0		

DESIGNED BY	DATE	SCALE
DRAWING NO.	02/00/00	AS INDICATED

APPROVAL	DATE

PROJECT NAME  
 CUSTOMER NAME  
 MODEL NO. CCC-HMS-060100  
 6'-0" X 10'-0" X 9'-3" H



**CARR CONCRETE**  
 Subsidiary of R.W. Sidley, Inc.

**CARR CONCRETE CORPORATION**  
 P.O. BOX 265  
 WAVERLY, WV 26184-0265  
 PHONE: (800)837-8918  
 FAX: (304)464-4013